

SLIDELIFT® SERIES

The GPST Series



GPST SPECIFICATIONS

The GPST is MAXON's latest addition to its Slider product range. This slider is explicitly designed for trucks and excels in performance as well as compact dimensions

- The GPST features the unique X1 technology which utilizes only one lift and one tilt cylinder, resulting in less parts (e.g. less hoses, valves, etc.) and consequently less maintenance costs
- The GPST utilizes two opposing cylinders to slide in and out resulting in a smooth and reliable deployment
- The GPST features a unique Quick Lock mechanism. The Quick Lock carries the load (not the rollers) and avoids platform bouncing when moving load from the truck to the platform

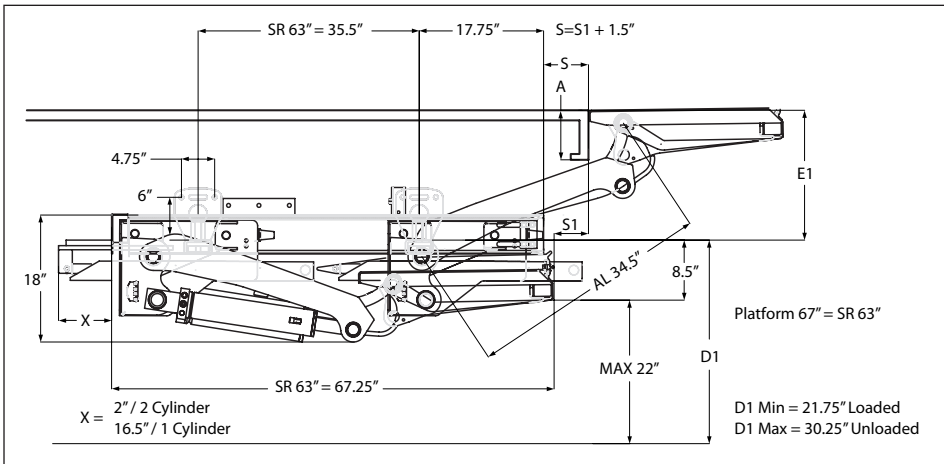

GPST-33 Lift Dimensions and Mounting Requirements

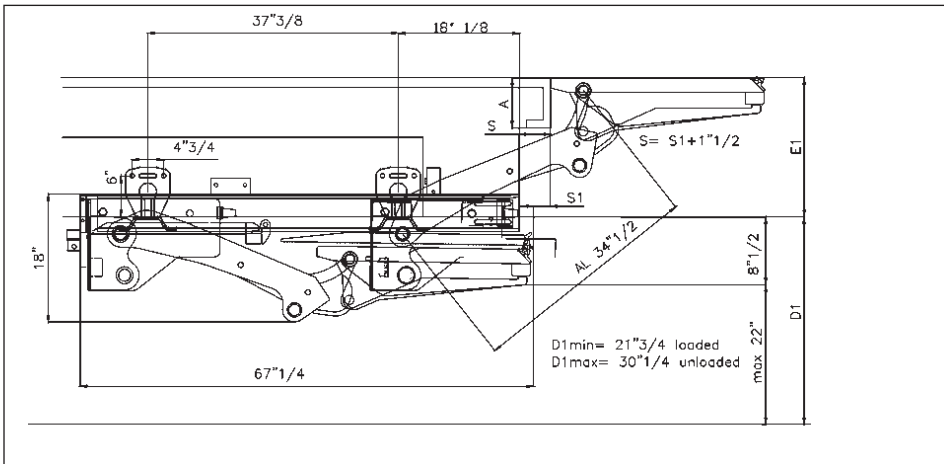

GPST-44 Lift Dimensions and Mounting Requirements

| MODEL CAPACITY | OVERALL WEIGHT | PLATFORM SIZE | BED HEIGHT |
|-----------------------|----------------|---------------|--------------------------|
| GPST-33 3,300 Lbs. | 1,600 Lbs. | 59" x 94.5" | 38" Laden 56" Unladen |
| GPST-44 4,400 Lbs. | 1,654 Lbs. | 67" X 94.5" | 38" Laden 56" Unladen |

| E1 | S 1Min | S 1Max | A Max |
|--------|--------|--------|-------|
| 15.75" | 3.23" | 6.75" | 6.25" |
| 17.75" | 2.13" | 5.5" | 7" |
| 19.75" | 0.79" | 2.75" | 7.5" |
| 21.75" | 0 | 2.75" | 8" |
| 23.5" | 0 | 0.75" | 8.75" |
| 26" | 0 | 0 | 9.75" |

Lift Dimensions and Mounting Requirements

SLIDELIFT® SERIES

The GPST Series

MAXON®

Standard Features

- Torsion spring assisted flip over section
- Dual cart stops
- Foot controls (can be disabled if not needed)
- Warning lights
- Maintenance-free bushings
- Completely sealed wiring harness
- Hand held control

Loadable Platform Space with Cart Stops Deployed

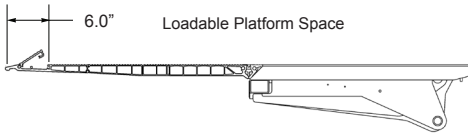

Unique X1 Technology

The unique X1 technology utilizes only one lift and one tilt cylinder. Resulting in less parts (e.g. less hoses, valves, etc.) and consequently less maintenance costs

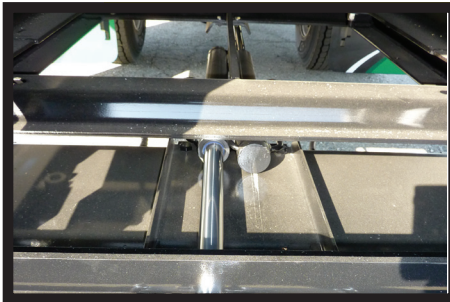

Double Acting Cylinders

The GPST slides in and out via double acting cylinders that ensure smooth and gentle sliding



Unique Locking Mechanism

The GPST's Quick Lock carries the load (not the rollers) and avoids platform bouncing when moving load from the truck to the platform

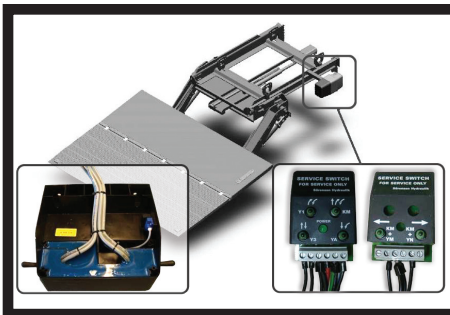

Electrical & Trouble Shooting Features

The GPST offers a service switch that allows you to trouble shoot the gate and to operate the gate if the main control fails. The wiring harness is fully sealed

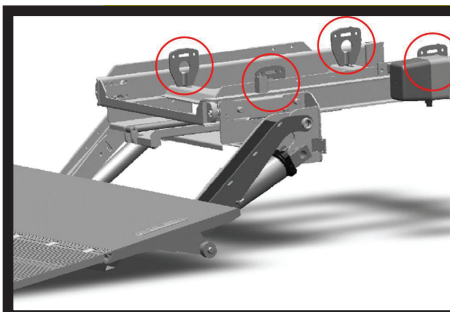

Installation

The GPST installation is efficient and thus cost effective. Simple and fast installation with 4 adjustable brackets (accommodates frame widths from 28" – 35"). It only requires 67" of rear overhang and accommodates bed heights from 38" – 56".

Distributed by:

M-195-1114